

2. Install Alarm Unit / Alarm-Einheit installieren

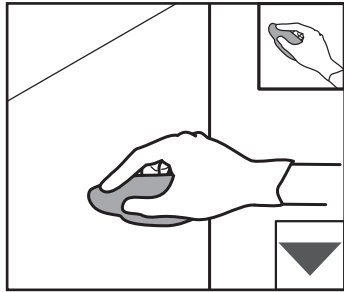

Clean surface of CNC machine where Alarm Unit will be mounted. Use the velcro locks on the backside of the Alarm Unit to attach box to the machine's surface. Recommended area is near machine's controller screen for high visibility.

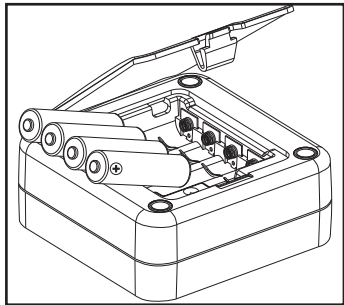

Flip open hatch on backside of Alarm Unit, insert 4x AA batteries (not included) into Alarm Unit, ⊕ side of battery facing away from springs. Close hatch.

LED color	Status
Blinking blue	Not connected
Blinking green	All Ok
Blinking red	Check battery
Solid red	Union leaked
(Buzzing sound)	Union leaked

Table above is LED status indicators for Alarm Unit and it is also displayed in front of the unit itself. The only way to reset Alarm unit after Union leaked is by pulling all the batteries.

Alarm Unit maximum operating temperature is 55° C.

For your own safety



1103-WLSB

contains the following transmitter modules

FCC ID : SH6MDBT50Q
 IC ID : 8017A-MDBT50QU



Note

Under Industry Canada regulations, this radio transmitter may only operate using an antenna of a type and maximum (or lesser) gain approved for the transmitter by Industry Canada. To reduce potential radio interference to other user, the antenna type and its gain should be so chosen that the equivalent isotropically radiated power (e.i.r.p) is not more than that necessary for successful communication.

This device complies with Part 15 of the FCC Rules. Operation is subject to the following two conditions: (1) this device may not cause harmful interference, and (2) this device must accept any interference received, including interference that may cause undesired operation.

FCC CAUTION

- Changes or modifications not expressly approved by the party responsible for compliance could void the user's authority to operate the equipment. This transmitter must not be co-located or operated in conjunction with any other antenna or transmitter.
- When installing it in a mobile equipment. (It is used within a distance of 20 cm from the antenna and the output power is required SAR test.)
- This equipment complies with FCC/IC radiation exposure limits set forth for an uncontrolled environment and meets the FCC radio frequency (RF) Exposure Guidelines and RSS-102 of the IC radio frequency (RF) Exposure rules. This equipment should be installed and operated keeping the radiator at least 20 cm or more away from person's body.

1. Install Detection Unit

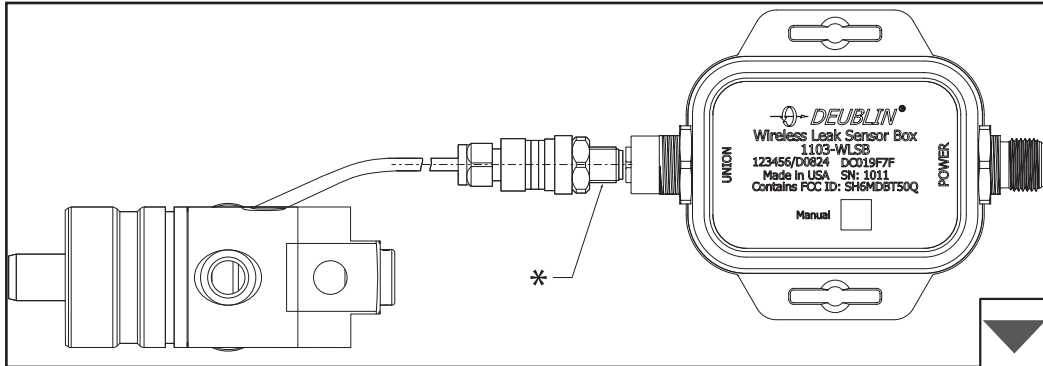

- * From rotating union male M12 connector, 4 position A coded

Locate cable from installed rotating union. Insert the connector into the Detection Unit end labeled "union", taking note of locating feature on connector for proper alignment. Twist until locked. Rotating union for reference only, NOT shown to scale and NOT shown in installed position.

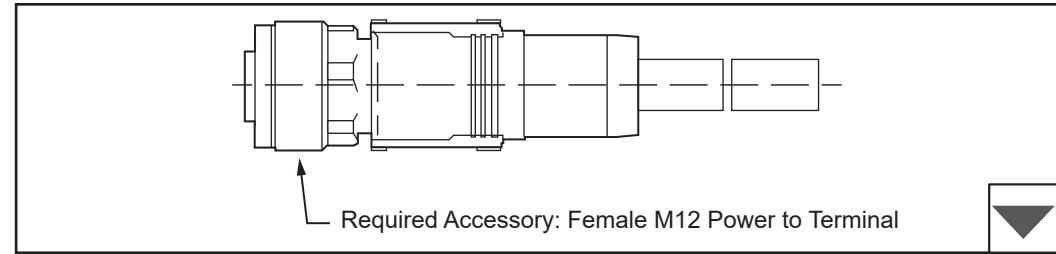

Female M12 connector for power terminal not included. Insert connector into Detection Unit end labeled "power", taking note of locating feature on connector for proper alignment. Twist until locked. Connect end of cable to machine/system power.

Recommended: HARTING 21348500491020
HARTING 21348500491050
HARTING 21348500491100

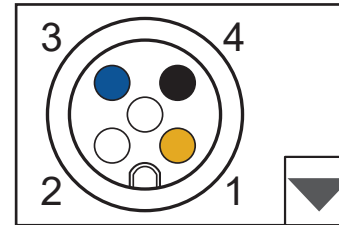

PIN	Cable Wire
PIN 1	+24 VDC – Brown
PIN 2	No Connection – White
PIN 3	Ground – Blue
PIN 4	No Connection – Black

Refer to power connector pin chart and verify that the correct wires are being used.

Operating Data: Detection Unit			
	Min	Normal	Max
Voltage	12 VDC	24 VDC	28 VDC
Current	–	21 mA	53 mA

Verify that terminal power supply is within operating condition range shown in table.