

1
REMOVE #1105-G HOUSING SNAP RING

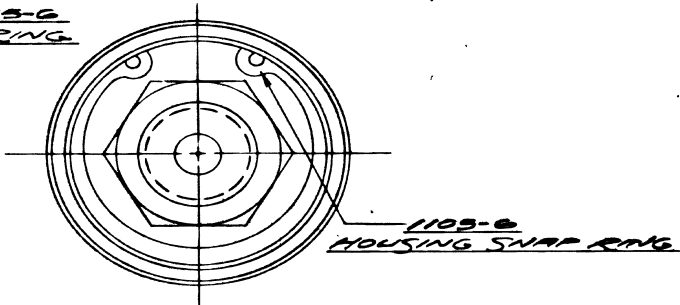

3

REMOVE #1102-65 MYLAR WASHER, #1102-16 FELT OILER, 1102-3 FLOATING SEAL, #1102-9 O-RING, 1102-10 SEAL GUIDE AND #1102-11 COIL SPRING FROM 1102-14 HOUSING.

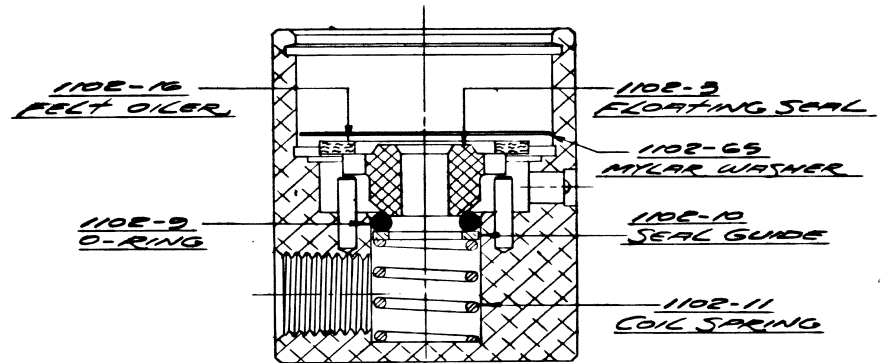

2
REMOVE ROTOR ASSEMBLY AS SHOWN

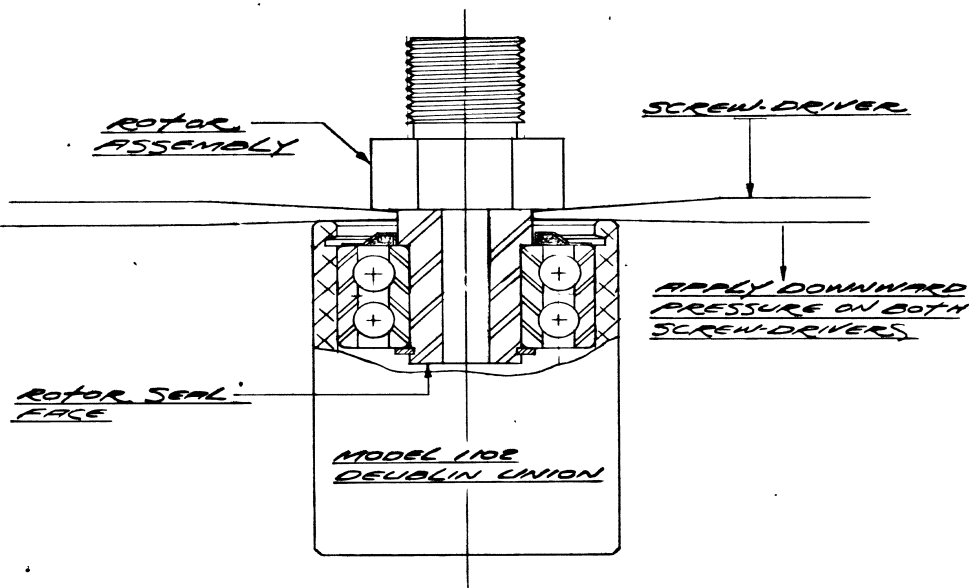

4

CHECK AREA OF BORE

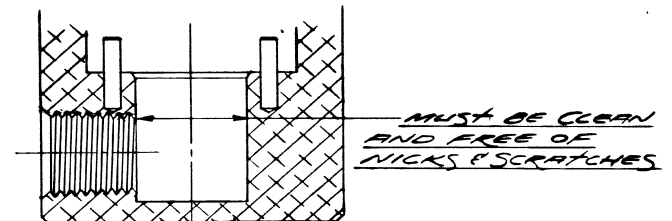

EXAMINE ROTOR SEAL FACE FOR SCORING. IF SEVERE SCORING IS EVIDENT THE ROTOR SHOULD BE REPLACED. IF LITTLE OR NO SCORING IS PRESENT, ROTOR CAN BE REUSED. ALSO INSPECT THE AMOUNT OF GREASE IN THE BALL BEARING, AND LUBRICATE IF REQUIRED.

(SHEET 1 OF 2)

G				MATERIAL	SCALE 2:1	DEUBLIN COMPANY NORTHBROOK, ILLINOIS, U.S.A.
F				DRAWN	DATE	
E				DATE	APP'D	
D						1102 UNION
C						TOLERANCES
B						FRACTIONS ± 0.10
A						DECIMALS AS SPECIFIED
LET	REVISION	DATE	SIGN	REMOVE BURRS AND BREAK ALL SHARP CORNERS 0.10 OR AS SPECIFIED REMOVE GREASE OR MACHINING OILS		ANGLES ± 1/2°

NO DA 35

5

WHEN ASSEMBLING DEUBLIN UNIONS, CLEANLINESS IS AN IMPORTANT FACTOR. ALL PARTS MUST BE FREE OF DIRT AND CHIPS. THE PARTS MAY BE CLEANED WITH CLOROTHENE, CARBON TETRACHLORIDE, ALCOHOL OR ANY GOOD CLEANING SOLVENT.

REBUILDING KIT PARTS LIST

- ROTOR, PRE-ASSEMBLED**
 (1) 1102-6 BALL BEARING
 (1) 1105-13 SNAP RING
 (1) 055-43 DUST SHIELD
 (1) 1102-11 COIL SPRING
 (1) 1102-9 O-RING
 (1) 1102-3 FLOATING SEAL
 (1) 1102-10 SEAL GUIDE
 (1) 1102-16 FELT OILER
 (1) 1102-65 MYLAR WASHER

6

CLEAN ROTOR SEAL FACE AND #1102-3 FLOATING SEAL. SEAL FACES MUST BE FREE OF ALL DIRT AND DUST.

7

ASSEMBLE #1102-11 COIL SPRING, #1102-10 SEAL GUIDE, #1102-9 O-RING, #1102-3 FLOATING SEAL & #1102-16 FELT OILER

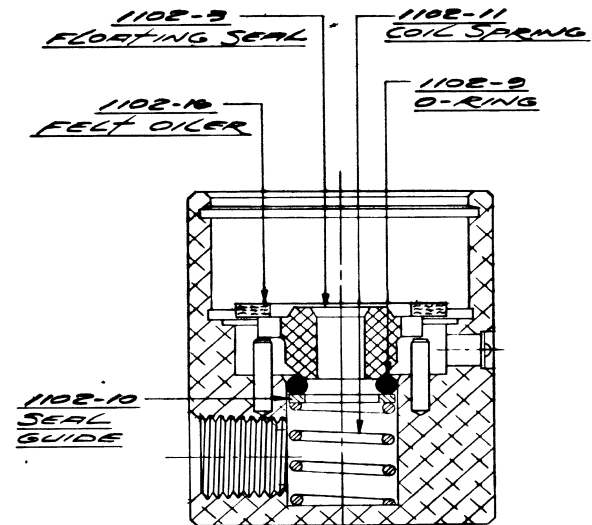

9

ASSEMBLE ROTOR ASSEMBLY

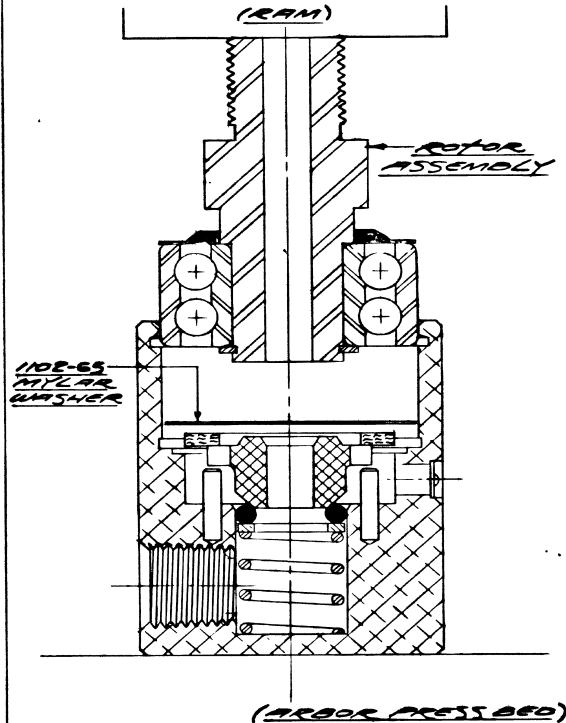

DA 35

TEST PROCEDURE

DEPRESS BALL AND APPLY BUBBLE SOAP

NOTE
 TEST UNION WITH 50 P.S.I. MINIMUM AIR PRESSURE BEFORE PERMANENT INSTALLATION

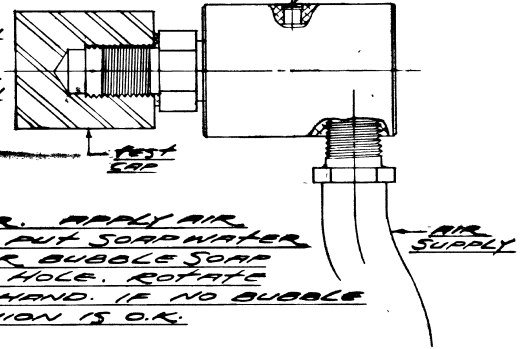

CAP ROTOR. APPLY AIR PRESSURE. PUT SOAP WATER SOLUTION OR BUBBLE SOAP OVER TEST HOLE. ROTATE ROTOR BY HAND. IF NO BUBBLE RAISES, UNION IS O.K.

10

ASSEMBLE #1105-6 HOUSING SNAP RING

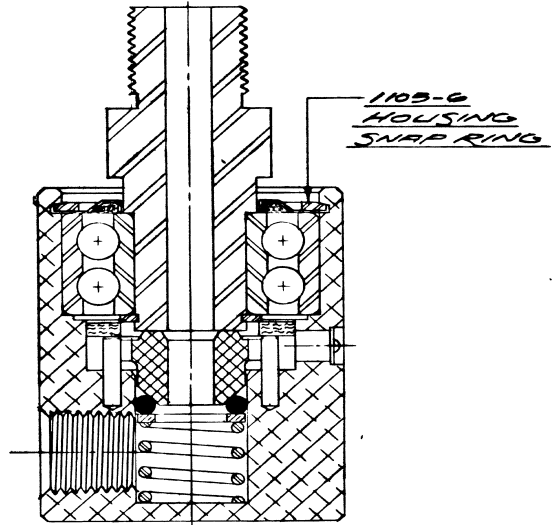

(SHEET 2 OF 2)

8

OIL #1102-16 FELT OILER AND ENTIRE FACE OF #1102-3 FLOATING SEAL WITH LOW VISCOSITY OIL, AND INSTALL #1102-65 MYLAR WASHER ON TOP OF FELT OILER.

G				MATERIAL	SCALE 2:1	DEUBLIN COMPANY NORTHBROOK, ILLINOIS, U.S.A. 1102 UNION TOLERANCES FRACTIONS ± .010 DECIMALS AS SPECIFIED ANGLES ± 1/2°	FILMED <input type="checkbox"/> NO DA 35
F							
E							
D							
C							
B							
A							
LET	REVISION	DATE	SIGN	ALL DIAMETERS TO BE CONCENTRIC WITH OOST I R OR AS SPECIFIED REMOVE BURRS AND BREAK ALL SHARP CORNERS .010 OR AS SPECIFIED. REMOVE GREASE OR MACHINING OILS			