

### Disassembly:

1. Step (Picture 1) Remove snapping 1+2 using snapping pliers (a)  
(Picture 2) Position Disassembly plate (b) between rotor 3 and housing 4 and lay it on the arbor press. Using the Disassembly rod (c) press the rotor 3 out of the housing 4.
2. Step (Picture 3) Remove snapping 6.  
(Picture 4) Position Disassembly plate (d) between the rotor 3 and the ball bearing 5. Press now the rotor through the ball bearing.
3. Step (Picture 5) Remove ball bearing 7 using the Disassembly rod (e) and the arbor press as shown in the drawing.
4. Step Remove teflon ring 8 and O-ring 9 with a long needle or something equivalent. Take caution not to scratch the bottom of the groove.

### Assembly:

1. Step (Picture 7) Carefully inspect the rotor diameter for grooves or scratchings. The surface roughness should be around  $Rz \leq 1,5$ . Light scratching could be polished with a fine grade of emery cloth.
2. Step (Picture 8) Laying the ball bearing 5 on the Disassembly plate (d) with the seal side up, insert the rotor end into the bearing and apply pressure with the arbor press to force the rotor through the bearing.  
(Picture 9) Assemble snapping 6.
3. Step (Picture 10) Assemble lightly greased O-ring 9 into the housing 4. Compress the teflon-ring 8 into a kidney-shape being carefully not to crack the ring. Assemble the teflon-ring onto the O-ring 9 into the groove of the housing.  
(Picture 11) Center the teflon-ring with a center bolt (e).
4. Step (Picture 12) Assemble the ball bearings 7, with the seal side up into the housing, by using the Assembly rod (f).  
(Picture 13) Reassemble the snapping 1 into its groove.
5. Step (Picture 14) Press the rotor 3 through the housing 4.  
(Picture 15) Reassemble snapping 2 into its groove.
6. Step (Picture 16) The UNION is now ready for the air test. Trickle a few drops of light motor oil into the "B"-ports and turn the rotor.  
Close the rotor with a lid using the 4xO-rings 10 for sealing.  
Connect an air fitting into the first "B" port and apply a bubble soap solution to the next channel. Turn the rotor. If no bubble is produced at all channels, the UNION is ready for reinstalation.

**a** Snapping pliers

Model	Order - No	Shaft	Order - No	Bore
379		ZGA-2		ZGJ-3
479		ZGA-3		ZGJ-3

**b**

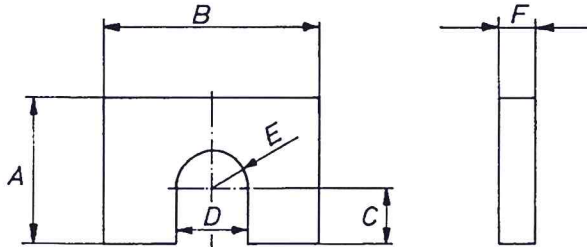

Disassembly plate

Model	Order - No	A	B	C	D	E	F
379	379-	100	120	35	42	21	10
479	479-	120	150	40	52	26	10

**c**

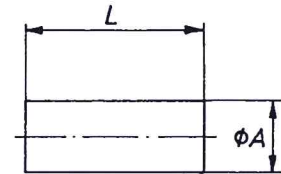

Disassembly rod

Order - No	A	L
379-	28	50
479-	38	50

**d**

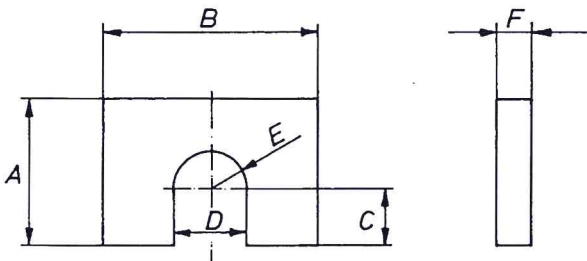

Disassembly plate

Model	Order - No	A	B	C	D	E	F
379	379-	140	160	45	70	35	10
479	479-	120	150	40	52	26	10

**f**

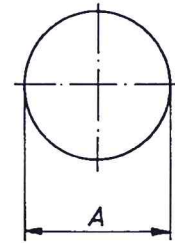
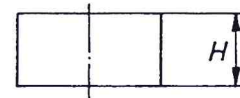

Assembly rod

Order - No	A	H
379-	28	50
479-	38	50

**e**

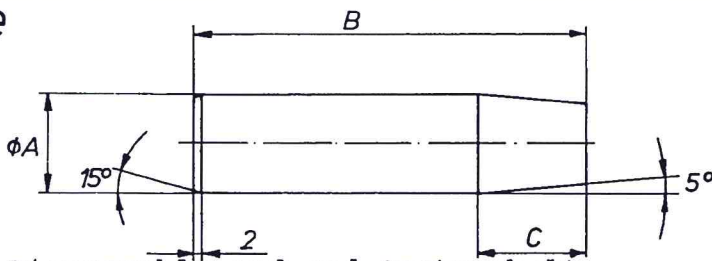

Disassembly rod and Center bolt

Model	Order -No	A	B	C
379	379-	37.8	170	30
479	479-	47,8	200	50

Other tools:

Grease; Oil ; Emery cloth (fine grade)

Needle ; Air fitting equivalent to the "B"-Connection ;

1

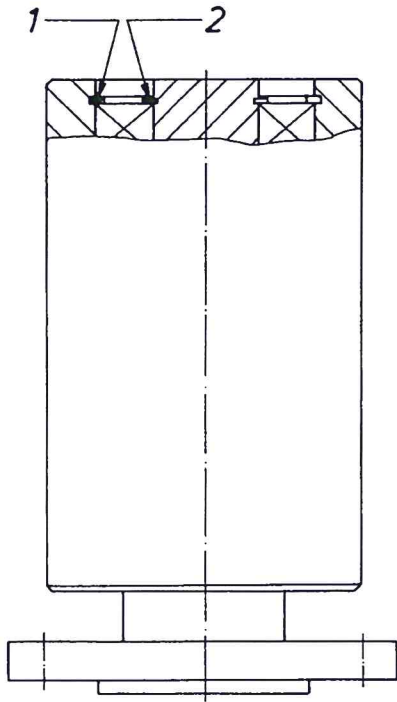

2

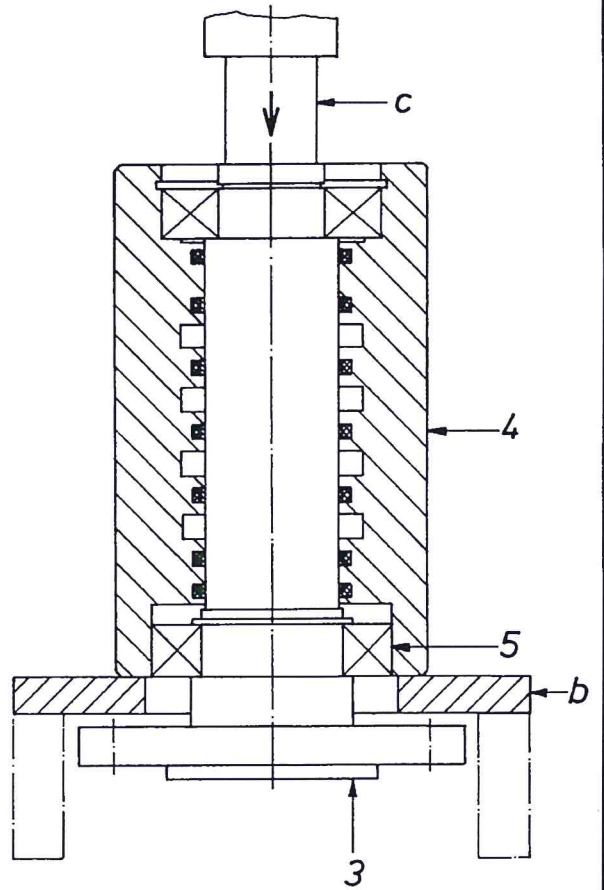

3

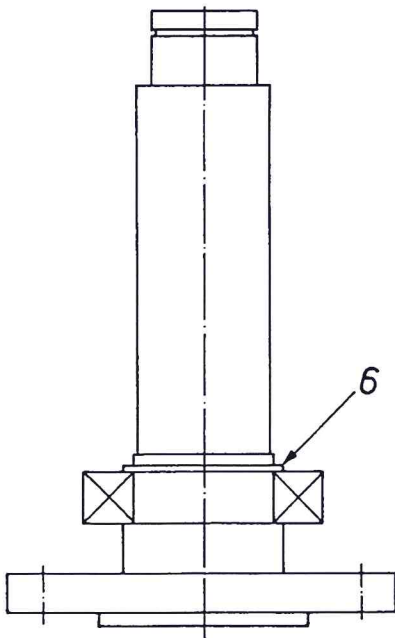

4

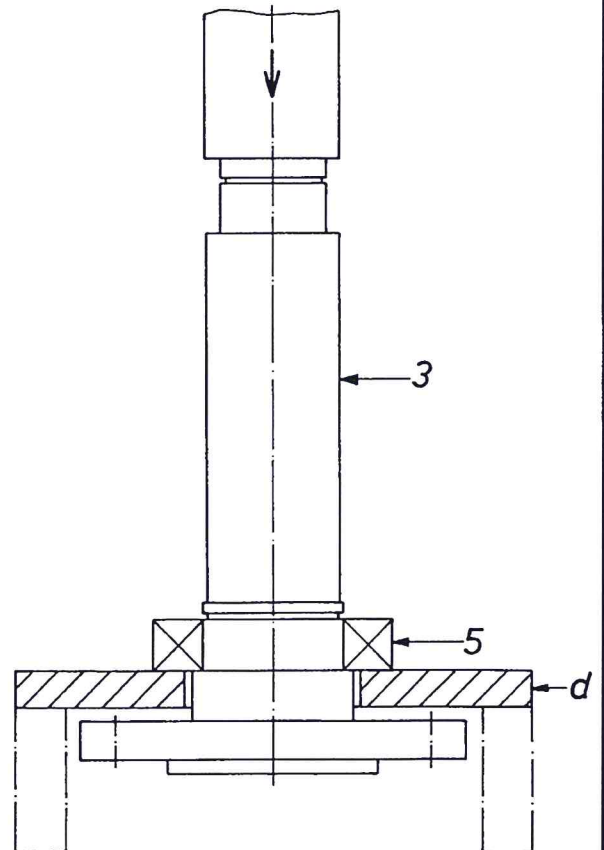



5

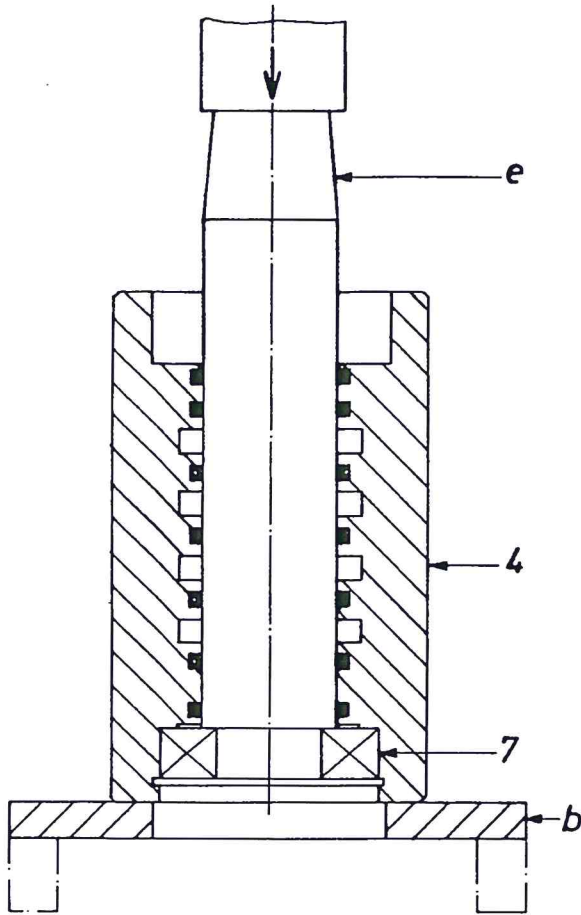

6

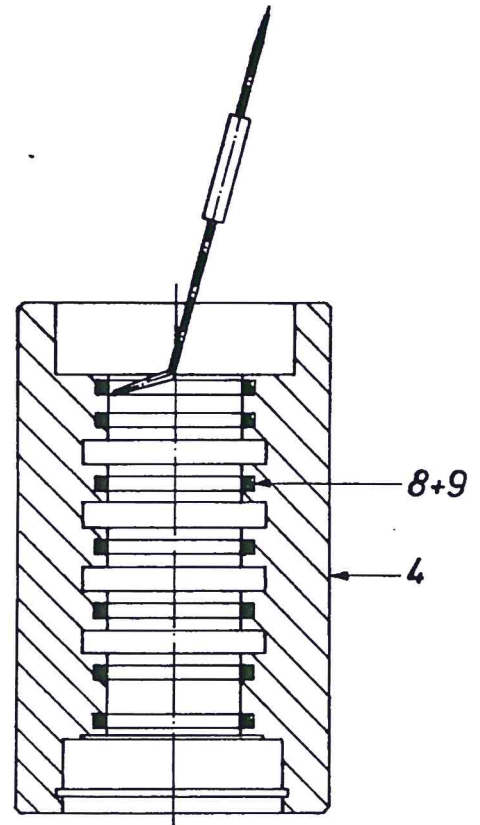

7

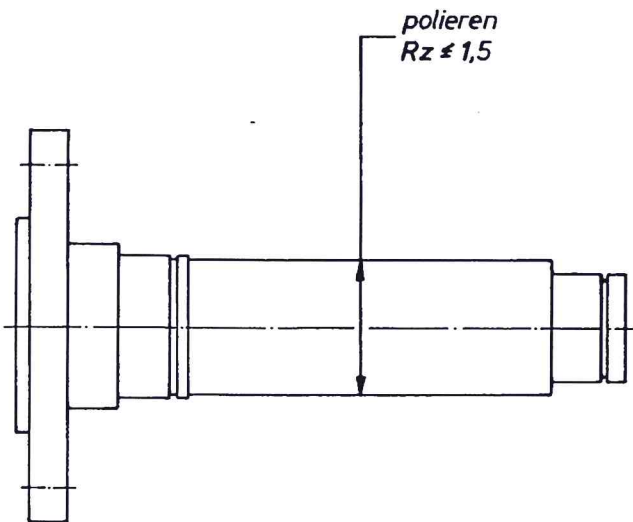

8

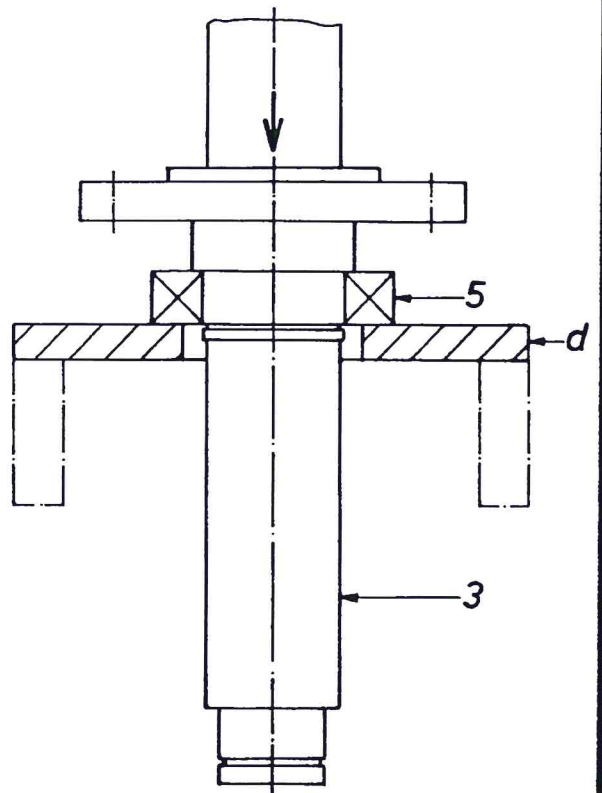

9

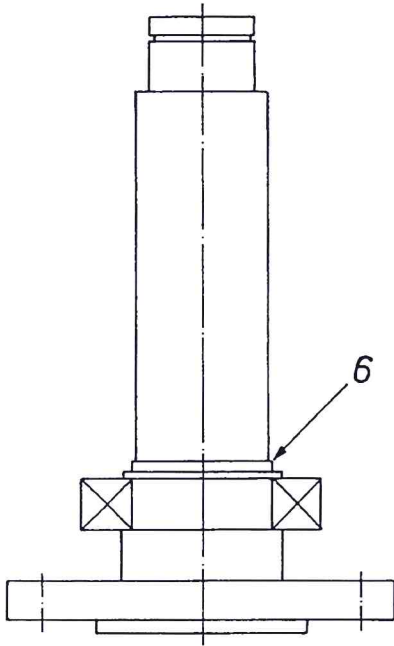

10

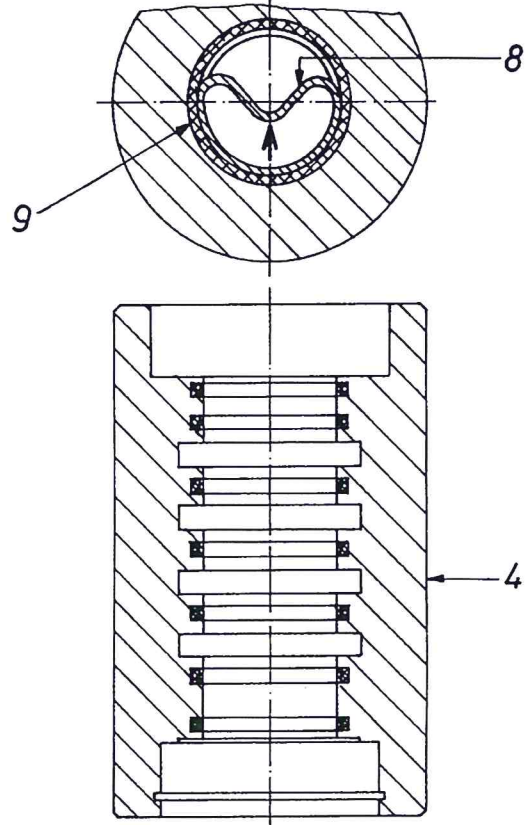

11

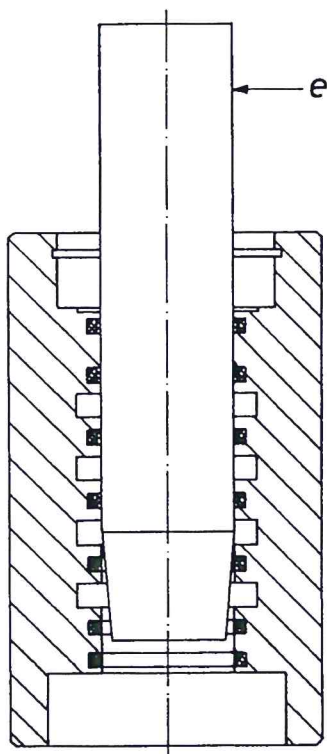

12

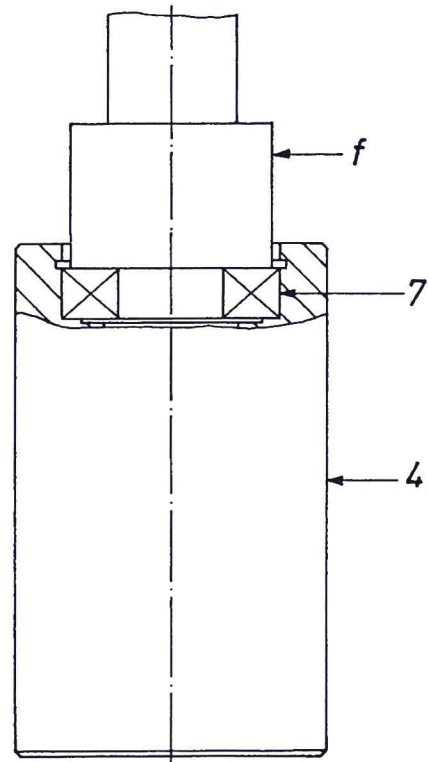

13

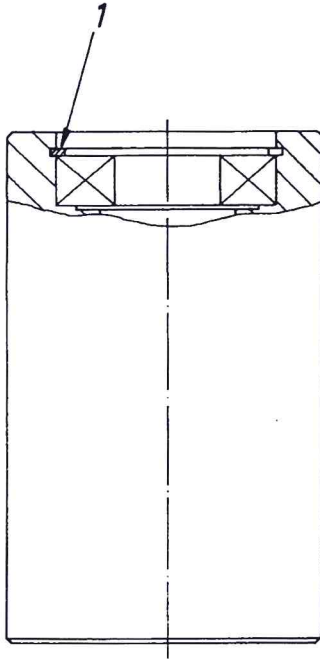

14

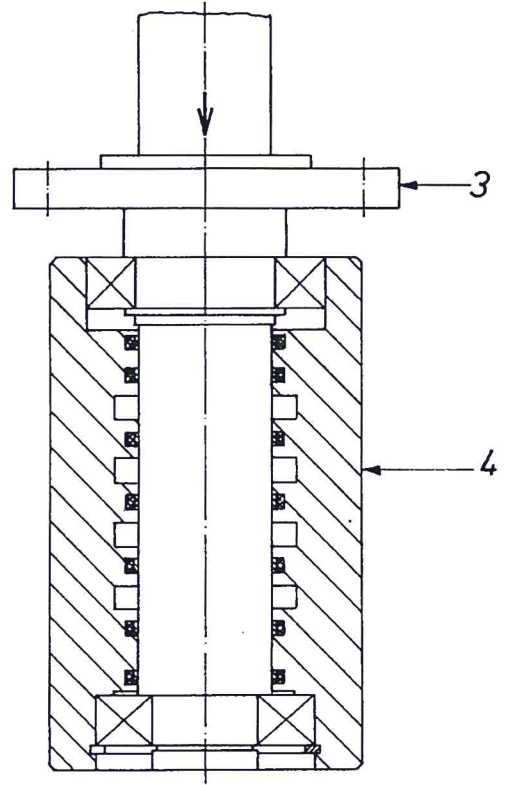

15

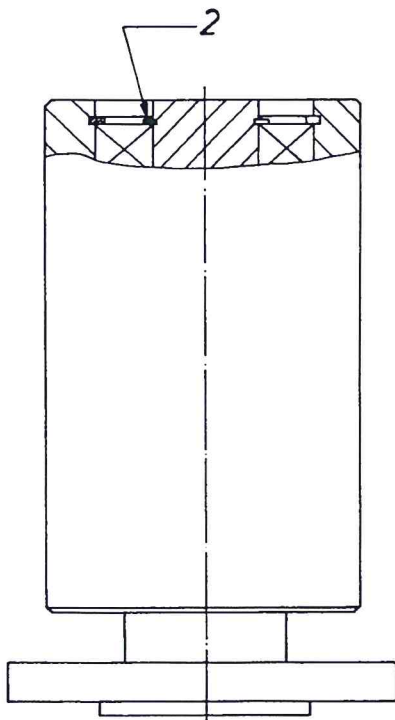

16

