



Rotating Unions



Series

**17/21, 2117, 1690, 1790, 1890, 1379, 1479, 2300, D, MPSS-000037
for air and hydraulic
with elastomeric seals**



Content

1	For your Safety	3
1.1	Intended Use	3
1.1.1	Application cylinder (Duo)	4
1.2	Misuse	4
1.3	Safety Instructions	5
1.3.1	Hazards due to hot surfaces	5
1.3.2	Hazards due to incorrect hoses	5
1.3.3	Hazards due to the media	5
1.3.4	Hazards by faulty installation	6
1.4	Structure of Pictograms	7
2	Information as to this Manual	7
3	Information on the Name Plate	7
4	Information on the Design	8
4.1	Filtering of the Medium	8
4.2	Compressed Air Purity Classes	8
4.3	Definition of Hydraulic Fluids	9
4.4	Optional 1379/1479: use of support sleeves for vacuum applications	9
4.5	Connecting Options of the Rotating Union at the Machine Shaft	9
4.6	Options of Hose Installation	10
4.6.1	Connection of hose to the rotating union	10
4.6.2	Observe the “paired” connection of the medium	10
4.6.3	Using an anti-rotation element	11
4.6.4	Optional: Connection of a leakage line	11
5	Installation	12
6	Information on the Operation	12
7	Storage	12
8	Maintenance	12
8.1	Maintenance Intervals	12
8.2	Daily Inspection	13
9	Trouble Shooting	13
9.1	Potential Causes for Errors and their Elimination	13
9.2	Pack Rotating Union for Transport	14
10	Disposal	15
10.1	Dispose of Packaging	15
10.2	Dispose of Rotating Union	15
11	Spare Parts	15

1 For your Safety

This chapter provides information on the safe handling of *DEUBLIN* rotating unions.

- For your own safety and the safety of other people read this operating manual carefully and completely prior to working on or with *DEUBLIN* rotating unions.
- This operating manual exclusively describes the rotating unions of the manufacturer *DEUBLIN*. In the further description/explanation the name “*DEUBLIN*” is left out for a better readability.
- This operating manual is a material part of the specified rotating unions. The operator is responsible for the personnel to take note of this manual.
- Always use the latest version of the operating manual, available under www.deublin.eu.
- The operator of the rotating unions shall not make any modifications or attachments to and retrofitting of the rotating union without the manufacturer’s consent.
- Please follow the additional instruction „Installation“ for a secure and correct installation of the rotating union. The installation instruction is included with the delivered union.

1.1 Intended Use

The rotating unions of the series 17/21, 2117, 1690/1790/1890, 1379/1479, 2300, D and MPSS-000037 are suitable for the following media:

Series	Medium ⁽¹⁾				
	Air	Water	Hydraulic oil	Brake fluid	Vacuum
17/21/2117	•		•	•	•
1690	•		•		•
1790					
1890					
1379	•		•		•
1479					
2300			•		
D		•	•		
MPSS-000037	•		•		

⁽¹⁾ In order to obtain the longest possible lifetime for rotating unions, the applied medium must meet certain requirements, which are defined in chapter 4.2.

The rotating unions put the medium under a certain pressure forcing it through the rotating machine components (e.g. machine shaft) to the load.

The rotating unions referred to are designed for non-potentially explosive environments and non-combustible media.

Details on the operating range of the rotating unions are provided in the catalogue and/or the model-specific installation drawing.

The rotating unions of the series 17/21, 2117, 1690/1790/1890, 1379/1479, 2300, D and MPSS-000037 can be used as single-passage or multi-passage option, depending on the number of connections.

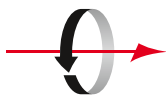

1.1.1 Application cylinder (Duo)

The following application is one example from a variety of applications.

This example shows how the cylinder is supplied with hydraulic oil or compressed air as medium.

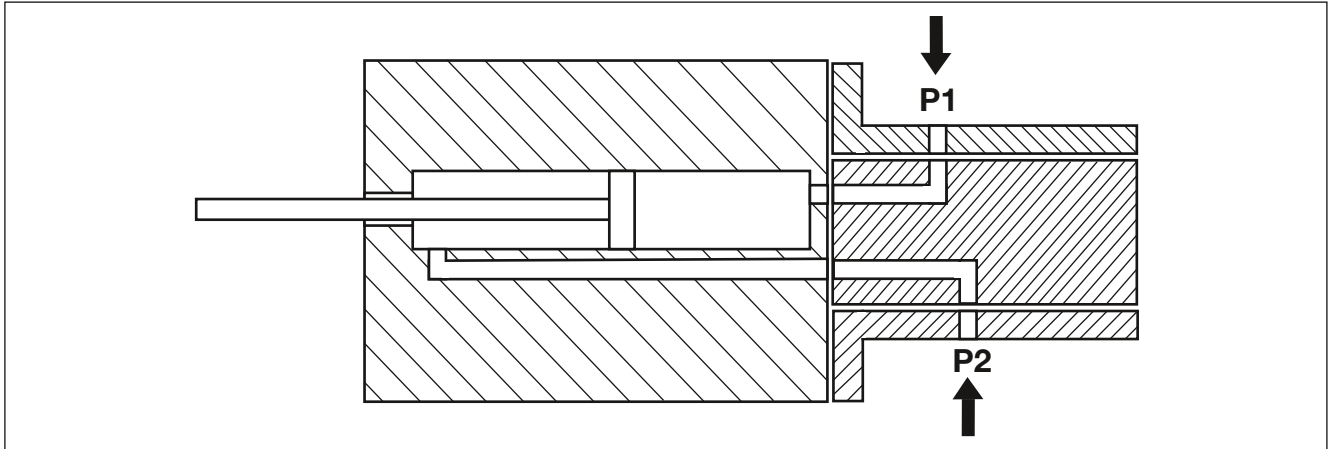

Fig. 1: Schematic diagram showing the power transmission to the cylinder

The hydraulic oil moves the piston of the cylinder. The mating connections of the rotating union are thereby used in pairs.

- In order to extend the piston, the hydraulic oil is supplied through connection P1 of the rotating union in front of the piston. P2 is un-pressurised.
- In order to retract the piston, the hydraulic oil is supplied through connection P2 of the rotating union behind the piston. P1 is un-pressurised.

Depending on the complexity of each application, the corresponding series with the required number of connections and channels can be used.

1.2 Misuse

This chapter provides information on known misuse of rotating unions of the 17/21, 2117, 1690/1790/1890, 1379/1479, 2300, D and MPSS-000037 series.

The rotating unions are not suitable for the areas and applications described herein. Use in such areas or for such applications constitutes a misuse endangering people and machines and is therefore prohibited. Always observe the operating data released by *DEUBLIN* on the model-specific drawing. It can be requested from *DEUBLIN*.

Prohibition for the following areas:

- Potentially explosive areas**
The rotating unions of the 17/21, 2117, 1690/1790/1890, 1379/1479, 2300, D and MPSS-000037 series shall not be used in potentially explosive areas, as they are not approved for the requirements in potentially explosive areas. Operation in such areas may cause explosions.
- Outdoor operation**
Inadequate protection against weather conditions can result in premature failure.

Prohibition for the following applications:

- Conveying of combustible media or hydrocarbons**
Combustible media or hydrocarbons may ignite or cause explosions.
Exception: Thermal oil within the admissible temperature range. Please observe the safety data sheet of the used thermal oil.
- Food**
Food, cleaning and disinfectant residues cannot be removed from the rotating unions. People may suffer poisoning.

- Connection to a piping system with excessive pressure**
If excessive pressure is applied to the rotating unions, supply pipes can come off and cause personal injury or property damage.
- Connection to fixed pipes**
If connection is via fixed pipes, the rotating unions may leak and the ball bearings may get damaged.
- Conveying of media which are too hot**
If the media exceed the maximum admissible temperature for the rotating union, the seals can be damaged which may result in leaky rotating unions and personal injury or property damage.
- Application in ambient temperatures/with media temperatures below 3°C**
Rotating unions may be damaged if they are operated at temperatures (ambient or media) below 3°C.
- Operation without a medium (dry run)**
If the rotating unions are operated without a medium, the sealing surface of the rotating unions might fail prematurely.
- Operation at maximum speed and with maximum pressure**
Speed and pressure must be adjusted to each another so that the rotating unions are not damaged or fail prematurely (see model-specific installation drawing).

This list is not comprehensive and will be updated with results from product observation.

1.3 Safety Instructions

This chapter provides information on the hazards when using rotating unions.

1.3.1 Hazards due to hot surfaces

Frictional heat and the temperature of the medium causes rotating unions to rise in temperature. Skin contact with heated rotating unions can cause injuries.

- Use safety gloves and PPE (Personal Protective Equipment) protecting against heat when handling the rotating union.
- Attach a clearly visible danger sign visibly on/next to the rotating union in order to warn of danger.

1.3.2 Hazards due to incorrect hoses

For the connection of the rotating union to the machine, you have to choose appropriate hoses for the respective medium, which meet the specifications for the application.

If you use incorrect hoses, they may become porous or burst. This can cause personal injury and/or property damage to components of the machine.

- Use only hoses which are suitable for the media, the maximum system pressure and the maximum temperature for the machine.

1.3.3 Hazards due to the media

When working on the rotating union, injuries can be caused by skin or eye contact with the media.

- Observe the safety instructions for the flow media. Observe the COSHH Safety Data Sheet for the flow media.

1.3.4 Hazards by faulty installation

If the rotating unions are installed incorrectly, hoses and connections may become leaky. The medium can escape. Depending on the medium, personal injury or property damage to the components of the machine may occur.

- Before installing the rotating union ensure that no feed pressure and no residual pressure is applied to the pipeline system of the machine.
 - Please follow the additional instruction "Installation" for a secure and correct installation of the rotating union. The installation instruction is included with the delivered union.
- Install the hoses to the rotating union prior to mounting it at the machine shaft. This does not apply to hoses with an SAE connection.
- Install the anti-rotation element on the rotating union, tension free.
- Make sure that the hoses are connected in compliance with the channel configuration of the rotating union. Pay attention to the model specific installation drawing.
- Install the rotating union on the machine using hoses only, in order to avoid stress on the rotating union.
- Install the hoses free from stress.
- Rotating Unions with leakage line: Install the rotating union in a way that the leaking medium can be carried away securely downward at the lowest point and that the drain line shows a fall (min. 15°).

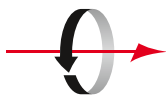

1.4 Structure of Pictograms

This chapter provides information on the meaning of the pictograms used in the manual.



Warning

Warning

Potentially dangerous situation, which may result in death or serious injury.



Note

Note

Potentially harmful situation in which the product or surrounding objects can be damaged.



Info

Application notes

and other useful information.

2 Information as to this Manual

The copyright as to this manual remains with *DEUBLIN*. Subject to changes!

- You can download the latest version of this manual under www.deublin.eu.
- Always use the latest version of the operating manual.

3 Information on the Name Plate

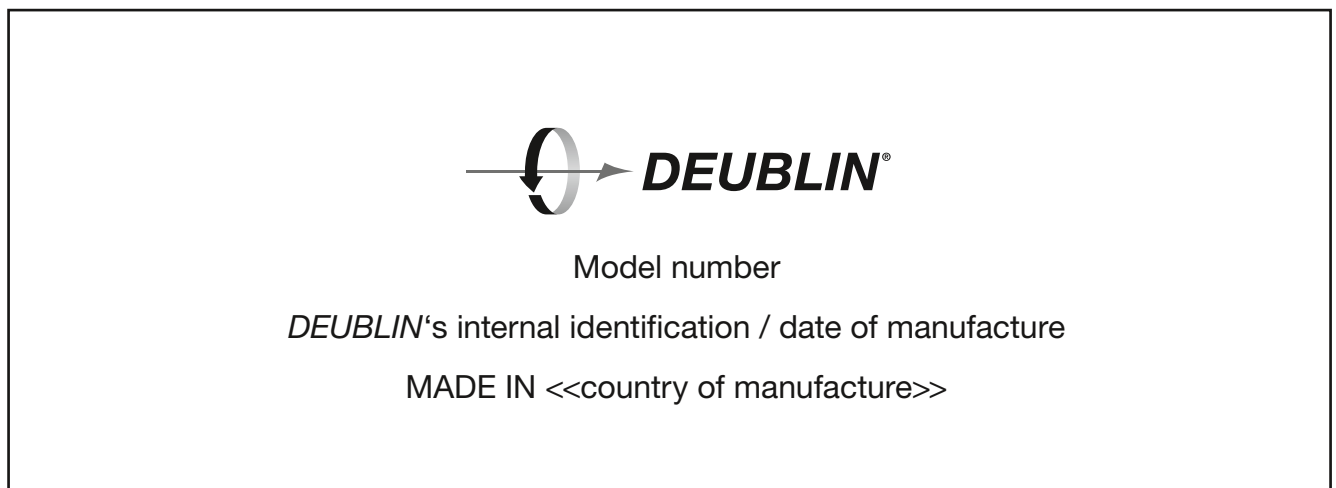

Fig. 2: Name plate

The coding of the model number is described in the catalogue. The model number corresponds to the order number.

4 Information on the Design

This chapter provides information as to which items have to be observed in the design in order to have a positive effect on the service life of the rotating union.



Info

You can obtain the drawings of the rotating unions from *DEUBLIN* to integrate the rotating union in your drawing.

You will require the model-specific installation drawing of your rotating unions to implement it into your design and to operate the rotating unions in a safe manner.

The model-specific installation drawing of the respective rotating union contains e.g.:

- torque moments of the union
- technical data
- tolerances
- approved media

4.1 Filtering of the Medium

Unfiltered media with a particle size of more than 60 µm, increased wear of the rotating union.

Please use the following classes of liquid media:

- Class 5 in accordance with ISO 4406:2017 Code 17/15/12 or
- Class 6 in accordance with NAS 1638

Determine the required filter performance data according to standard ISO 16889:2008 to achieve a maximum particle size of 60 µm.



Info

The larger the particles in the media, the higher the wear of the rotating union is. The higher the total of all particles (polluting load), the higher the wear.

- Insert a filter in front of the rotating union which filters particles with a size of 60 µm and larger from the media.

4.2 Compressed Air Purity Classes



Info

This chapter only applies for series 17/21, 1217, 1690/1790/1890 and MPSS-000037.

To ensure the longest possible service life of the rotating union, *DEUBLIN* recommends using a compressed air purity class according to ISO 8573-1:2010 [6:4:4]. This results in the following parameters for the compressed air:

Particles	Water	Oil
Mass concentration Cp [mg/m ³]	Pressure dewpoint [C°]	Concentration of total oil [mg/m ³]
0 < Cp ≤ 5	≤ +3	≤ 5

4.3 Definition of Hydraulic Fluids

The hydraulic fluid that is used must correspond to the following definition: Mineral oils according to DIN 51524 (HL; HLP)/ ISO 6743/4 (HL, HM, HV) in viscosity classes 10, 22, 32, 46, 68 and 100 mm²/s).

4.4 Optional 1379/1479: use of support sleeves for vacuum applications

For vacuum applications of series 1379/1479, support sleeves are used for the connections to the flange. These support sleeves prevent the O-rings from being drawn into the channel in the event of a vacuum which would cause the rotating unions to leak.

Support sleeves and installation instructions are supplied together with the rotating unions of series 1379 and 1479.



Note

Component damage due to incorrect installation

If the support sleeves are inserted into the channel with O-ring already in position, you risk crimping and damaging the O-rings.

- Remove the O-rings, insert the support sleeves, and then insert the O-rings.

4.5 Connecting Options of the Rotating Union at the Machine Shaft

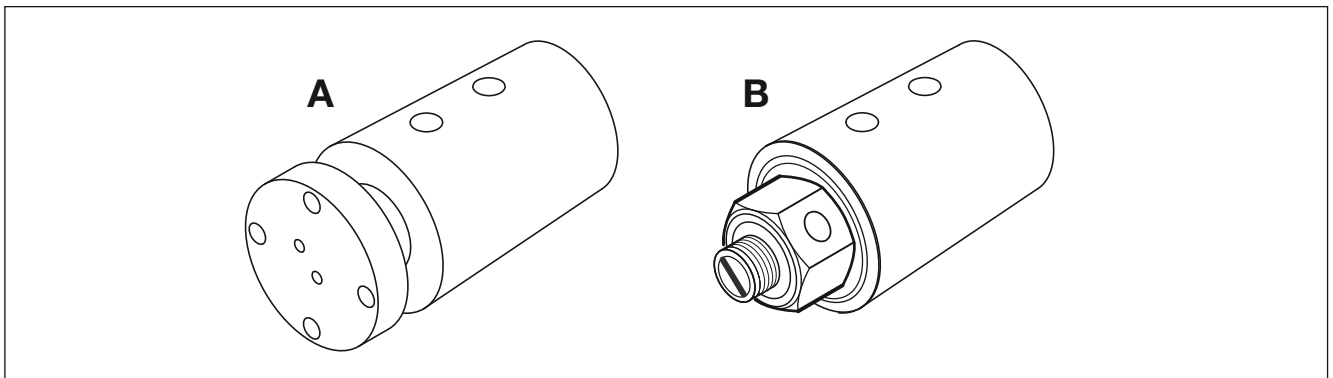

Fig. 3: Options for the installation on the machine shaft

The rotating unions are mounted to the machine shaft via the rotor. The following rotor options are available:

- Option (A): The rotor is equipped with a flange.
- Option (B): The end of the rotor is threaded.

The rotor provides the connection between rotating union and shaft. Therefore it is important to carefully design the shaft in compliance with the specifications in the installation drawing for each specific rotating union. Deviations might result in leakages and uneven movements of the rotating unions.

4.6 Options of Hose Installation

The following examples show how to install the hoses at the rotating unions.

These connecting options ensure that the hoses do not transfer stress to the rotating unions when the machine shaft moves.

- Please pay attention to the chapter “1.3 Safety Instructions” regarding the design.

4.6.1 Connection of hose to the rotating union

The hoses must be installed without stress and bends so that they do not apply any forces to the rotating union. The following figures show examples of installation.

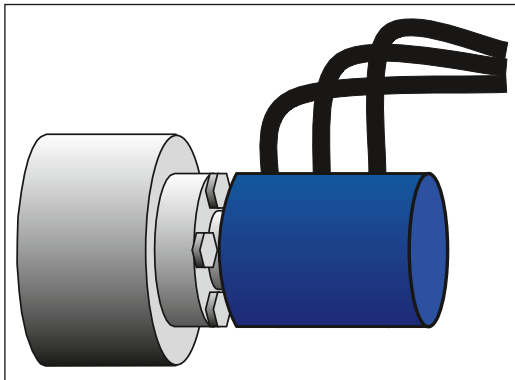

Connect the rotating union with flexible hoses. During operation, flexible hoses prevent lateral loads on the bearings of the rotating unions. Please observe chapter 1.3.4.

Fig. 4: Lateral connection of the hoses

4.6.2 Observe the “paired” connection of the medium

The connections for the rotating unions are arranged in “paired” connections, which are separately sealed. In order to prevent the mixing of different media, you must be sure to supply and return only one medium through “paired” connections.

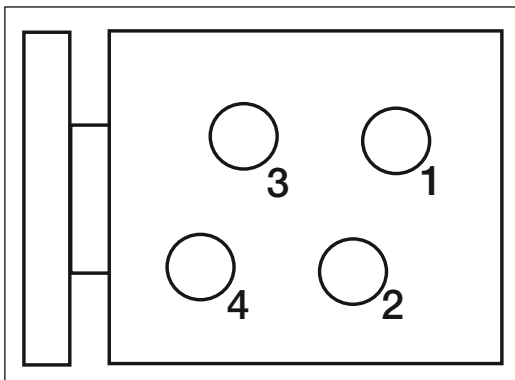

Possible “paired” connections:

- Connection 1 and 2
- Connection 3 and 4

For rotating unions with further connections, the “paired” connections are arranged in the same way.

Fig. 5: Example of “paired” connections

4.6.3 Using an anti-rotation element

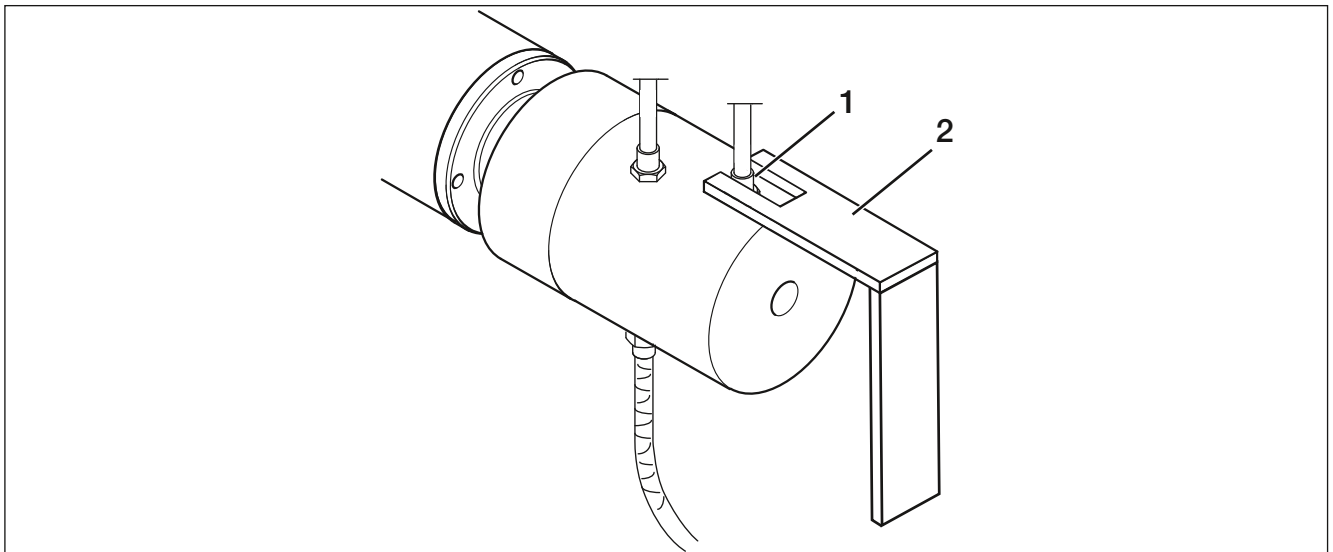

Fig. 6: Example of an anti-rotation element

The rotating union must be secured against rotation during operation using an anti-rotation element **(2)**. The connections of the hoses **(1)** can be used as torque supports. A fork head may e.g. be installed on-site to serve as an anti-rotation element at a hose connection.

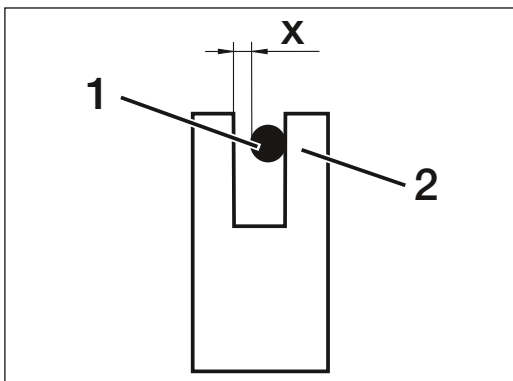

Fig. 7: Top view torque support

The connector of the hose **(1)** may in this example only touch against one side of the bracket **(2)** of the anti-rotation element so that a clearance **(X)** remains between the other side of the bracket and the hose connector.

4.6.4 Optional: Connection of a leakage line

To prevent surrounding components from being damaged by escaping medium, you can connect a leakage line to some rotating unions with separate leakage line, if required.

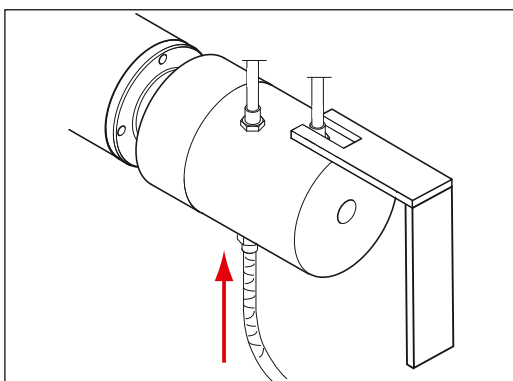

Fig. 8: Schedule connection of leakage line

Some rotating unions are provided with relief bores (leakage connections) for ventilation and leakage discharge.

- When used in dirty environment, we recommend protecting the leakage holes against penetrating dirt. If you close all relief bores, pressure builds up resulting in the premature wearing out of seals.
- Position the rotating union in a way that you can always connect the leakage line in 6 o'clock position (at the lowest point) to a leakage hole.
- The leaking medium has to be conveyed pressureless back to the tank.

5 Installation

The union installation is described in an additional manual which is supplied with each rotating union. Please follow the additional instruction "Installation" for a secure and correct installation of the rotating union. The instruction "Installation" is available online under www.deublin.eu.

- Ensure that the person installing the rotating union receives the following information:
 - Position and location of the rotating union in the machine
 - Information on the media
 - Plan for connection of hoses
 - Position of leakage line
 - Information on how to mount an anti-rotation element provided by the customer
 - Installation drawing for each specific model

6 Information on the Operation



Note

Damage to components due to operation without medium (dry running)

If your rotating union model is intended for operation with a medium but it is operated without the medium, the sealing surfaces of the rotating unions will be damaged.

- Ensure that the rotating unions are operated with a medium.
- Switch off the plant/machine, if the rotating unions are operated without medium.

7 Storage



Note

Damage of component due to incorrect storage

If you store the rotating unions incorrectly, they become leaky or get damaged.

- Store the rotating unions in a dry space between 3 °C and 40 °C.
- Rotating unions should not be stored for more than two years.

8 Maintenance

This chapter provides information on how to extend the service life of the rotating unions by means of maintenance.

8.1 Maintenance Intervals

You can avoid early wear of the rotating unions, if you adhere to the maintenance intervals described herein.



Warning

Risk of injury due to hot surfaces

Frictional heat and the temperature of the medium causes rotating unions to rise in temperature. Skin contact with heated rotating unions can cause injuries.

- Before starting to work on the rotating union, allow the machine to cool down.
- Use safety gloves and PPE (Personal Protective Equipment) protecting against heat or cold depending on the application of the rotating unions.

Re-lubrication is not necessary.



Info



8.2 Daily Inspection

Check the rotating unions for tightness.



Warning

Risk of injuries due to applied line pressure

If you have to work on the rotating union and feed pressure of the medium is applied or there is residual pressure in the piping system of the machine, the medium can escape under pressure when releasing the connections. You and other people may suffer severe injuries.

- Ensure that no feed pressure is applied.
- Ensure that there is no residual pressure in the piping system.

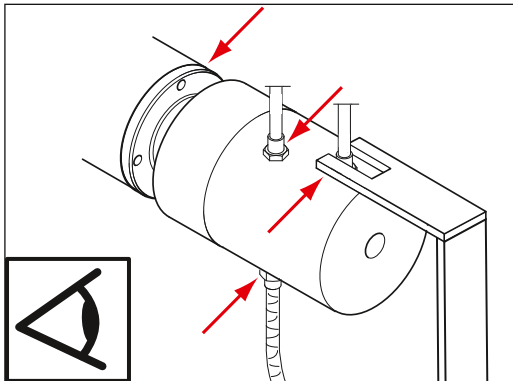

Fig. 9: Inspect visually

During the operation of the machine, leakage might occur, the time period is subject to the extent which the rotating unions are used.

- Carry out daily visual inspections in order to check whether leakage occurred at the rotating union (see arrows).

If you detect leakage:

1. Stop the machine.
2. Replace worn out or leaking rotating unions with new rotating unions.
3. Replace defective hoses with new hoses.
4. Seal leaking connections.

9 Trouble Shooting

This chapter provides the following information:

1. Which problem may occur?
2. What could be the cause of the problem?
3. How can you eliminate this problem?



Info

Do not disassemble the rotating unions for repair. This invalidates the warranty claim.

9.1 Potential Causes for Errors and their Elimination



Warning

Risk of injuries due to applied line pressure

If you have to work on the rotating union and feed pressure of the medium is applied or there is residual pressure in the piping system of the machine, the medium can escape under pressure when releasing the connections. You and other people may suffer serious injuries.

- Ensure that no feed pressure is applied.
- Ensure that there is no residual pressure in the piping system.

Error	Potential causes	Elimination
Rotating union is leaky after installation	Incorrect installation	<ol style="list-style-type: none"> 1. Stop the machine. 2. Ensure that the connections are sealed according to the manual "Installation". 3. Ensure that all hoses are installed without stress. 4. Ensure that all seal faces are clean. 5. Ensure that the anti-rotation element is installed without stress.
	Seal faces of the rotating union are damaged	<ol style="list-style-type: none"> 1. Pack rotating union. 2. Send rotating union to <i>DEUBLIN</i> for overhaul/service.
Rotating union leaks before the end of the expected service life	Medium is contaminated	<ol style="list-style-type: none"> 1. Stop the machine. 2. Drain medium. 3. Send rotating union to <i>DEUBLIN</i> for overhaul/service, if required. 4. Flush the piping system of the machine. 5. Mount new filter. 6. Fill in new medium.
	Rotating union is not designed for the respective application	<ol style="list-style-type: none"> 1. Ensure that the correct <i>DEUBLIN</i> Rotating Union is used. 2. Contact <i>DEUBLIN</i> if required.
Rotating union runs untrue or wobbles	Thread and/or concentricity outside the admissible tolerance.	<ol style="list-style-type: none"> 1. Stop the machine. 2. Remove rotating union. 3. Manufacture new thread or flange. 4. Mount the rotating union according to installation instructions.
	Rotating union is mounted incorrectly.	<ol style="list-style-type: none"> 1. Stop the machine. 2. Remove rotating union. 3. Mount the rotating union according to installation instructions.

9.2 Pack Rotating Union for Transport

The rotating union has to be protected against mechanical impact and humidity during transport to ensure that the rotating union will arrive at *DEUBLIN* without being damaged.

1. Dismount the rotating union in reverse order of the installation (see Installation).
2. Ensure that the rotating union is free from the respective media.
3. Use a cardboard box, which is suitable for the weight of the rotating union.
4. Cushion the base of the cardboard box with a soft material, e.g. air bubble film.
5. Wrap the rotating union with a soft material, e.g. air bubble film.
6. Ensure that no packing material or dirt can penetrate the opening of the rotating union.
7. Position the rotating union in the middle of the cardboard box.
8. Fill the free space around the rotating union with newspaper or another suitable material.
9. Close the cardboard box by means of tape.

10 Disposal

10.1 Dispose of Packaging

- Dispose of the packaging (cardboard box and plastics) according to the national standards, regulations and directives.

10.2 Dispose of Rotating Union

Mainly, the rotating unions consist of metals, which can be reused within the reclamation of scrap. Decontaminate unions / parts and dispose of in an “Environmentally Friendly” way.

- Dismount the rotating union in reverse order to the installation (see Installation).
- Flush the rotating union.
- Collect the dirty flushing media.
- Dispose of the collected flushing media according to the national standards, regulations and directives.
- Observe the instructions of the producer of the media.
- Dispose of the rotating union according to the national standards, regulations and directives.

In case of repair, *DEUBLIN* disposes of all used parts.

11 Spare Parts

The rotating unions have a limited service life and include wearing parts. All static and dynamic sealing elements of a component are considered wearing parts, as well as ball bearings.

Repair kits are available for series 17/21, 2117, 1690/1790/1890 and 1379/1479, 2300 of the rotating unions and can be obtained from *DEUBLIN*. No repair kits are available for models of the D and MPSS-000037 series. Please ask your *DEUBLIN* Service.

You need special tools and repair instructions for repair of the rotating unions, which can be obtained from *DEUBLIN* as well.



Info

Note

If you do not want to repair your rotating union on your own, *DEUBLIN* will be pleased to help you. If requested, *DEUBLIN* will exchange all wearing parts and clean all components of the rotating union. Before repaired rotating unions leave the premises, they will be subjected to an operational check. The repaired rotating union is returned with a standard “*DEUBLIN* Warranty” valid for 12 months.

Reliability

Many years' experience, ongoing liaison with customers, innovations sourced inhouse and from suppliers place *DEUBLIN* in a position providing reliable Rotating Unions at the highest level.

When it comes to concrete applications, maximum service life is guaranteed by matching the sealing to the respective medium.

The service life is also equally maximized by maintaining cleanliness when storing and handling the Rotating Union and by adhering to the guidelines issued by *DEUBLIN* in respect of the conditions on the customer's premises.

EUROPE

DEUBLIN Germany

Florenz-Allee 1
55129 Mainz, Germany
Phone: +49 6131-49980
Fax: +49 6131-4998109
e-mail: info@deublin.de

DEUBLIN Italy

Via Guido Rossa 9 - Loc. Monteveglio
40053 Comune di Valsamoggia (BO), Italy
Phone: +39 051-835611
Fax: +39 051-832091
e-mail: info@deublin.it

DEUBLIN Austria

Lainzer Straße 35
1130 Wien, Austria
Phone: +43 1-8768450
Fax: +43 1-876845030
e-mail: info@deublin.at

DEUBLIN France

61 Bis, Avenue de l'Europe
Z.A.C de la Malnoue, Emerainville
77436 Marne-la-Vallée Cedex 2, France
Phone: +33 1-64616161
Fax: +33 1-64616364
e-mail: service.client@deublin.fr

DEUBLIN Poland

ul. Bierutowska 57-59
51-317 Wrocław, Poland
Phone: +48 71-3528152
Fax: +48 71-3207306
e-mail: info@deublin.pl

DEUBLIN Russia

ul. Kosygina, 13, 5th entrance, 1st floor
Moscow, 119334, Russia
Phone: +7 495-647 1434
Fax: +7 495-938 8949
e-mail: info@deublinrussia.ru

DEUBLIN Spain

C/ Lola Anglada, 20 local 1
08228 Terrassa, Spain
Phone: +34 93-221 1223
Fax: +34 93-221 2093
e-mail: deublin@deublin.es

DEUBLIN United Kingdom

6 Sopwith Park, Royce Close, West Portway
Andover SP10 3TS, UK
Phone: +44 1264-33 3355
Fax: +44 1264-33 3304
e-mail: info@deublin.co.uk

AMERICA

DEUBLIN USA

2050 Norman Drive
Waukegan, IL 60085-6747 U.S.A
Phone: +1 847-689 8600
Fax: +1 847-689 8690
e-mail: customerservice@deublin.com

DEUBLIN Brazil

Rua Fagundes de Oliveira, 538 - Galpão A11
Piraporinha
09950-300 - Diadema - SP - Brasil
Phone: +55 11-2455 3245
Fax: +55 11-2455 2358
e-mail: deublinbrasil@deublinbrasil.com.br

DEUBLIN Mexico

Norte 79-A No. 77, Col. Claveria
02080 Mexico, D.F.
Phone: +52 55-5342 0362
Fax: +52 55-5342 0157
e-mail: deublinmexicocs@deublin.com

ASIA

DEUBLIN China

No. 2, 6th DD Street,
DD Port Dalian, 116620, China
Phone: +86 411-8754 9678
Fax: +86 411-8754 9679
e-mail: info@deublin.cn

Shanghai Branch Office

Room 15A07, Wangjiao Plaza
No. 175 East Yan'an Road, Huangpu District
Shanghai 200002
Phone: +86 21-5298 0791
Fax: +86 21-5298 0790
e-mail: info@deublin.cn

DEUBLIN Asia Pacific

51 Goldhill Plaza
#17-02 Singapore 308900
Phone: +65 6259-92 25
Fax: +65 6259-97 23
email: deublin@singnet.com.sg

DEUBLIN Japan

2-13-1, Minamihanayashiki, Kawanishi City
Hyogo 666-0026, Japan
Phone: +81 72-757 0099
Fax: +81 72-757 0120
e-mail: customerservice@deublin-japan.co.jp

2-4-10-3F, Ryogoku, Sumida-ku

Tokyo 130-0026, Japan
Phone: +81 35-625 0777
Fax: +81 35-625 0888
e-mail: customerservice@deublin-japan.co.jp

1-9-2-4F, Mikawaanjo-cho, Anjo City

Aichi 446-0056, Japan
Phone: +81 566-71 4360
Fax: +81 566-71 4361
e-mail: customerservice@deublin-japan.co.jp

DEUBLIN Korea

Star Tower #1003, Sangdaewon-dong 223-25,
Jungwon-gu, Seongnam-si, Gyeonggi-do,
South Korea
Phone: +82 31-8018 5777
Fax: +82 31-8018 5780
e-mail: customerservice@deublin.co.kr