

CONFIDENTIAL
 THIS DOCUMENT CONTAINS CONFIDENTIAL AND PROPRIETARY
 INFORMATION OF DEUBLIN COMPANY. COPYING, USE,
 TRANSMISSION, DISTRIBUTION, AND DISCLOSURE ARE SUBJECT
 TO THE TERMS AND CONDITIONS CONTAINED IN YOUR
 AGREEMENT WITH DEUBLIN COMPANY. ALL RIGHTS RESERVED.

NOTES:

① - PIPE LENGTH.

② - SEALS SHOULD BE REPLACED WHEN "X" DIMENSION EXCEEDS 4.8.

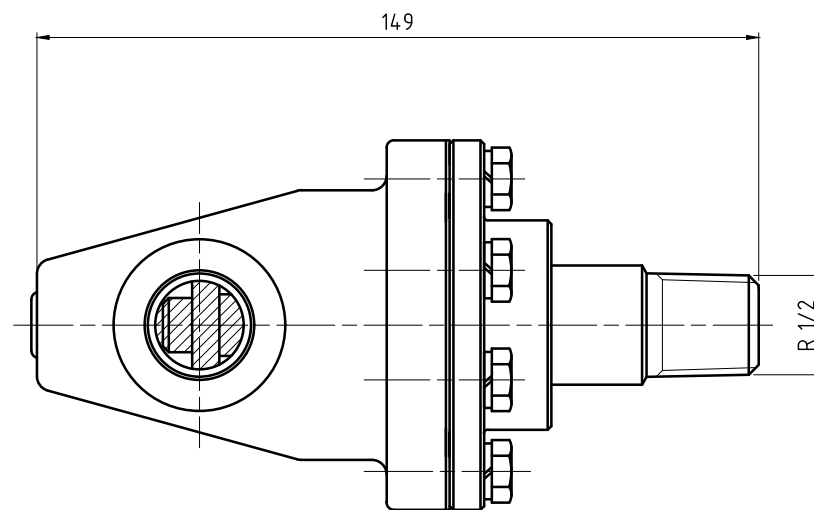
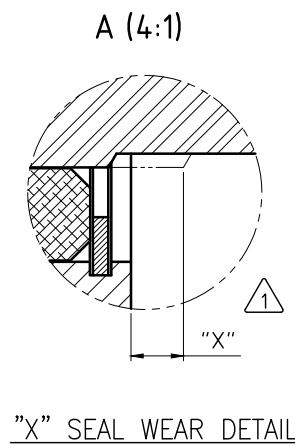
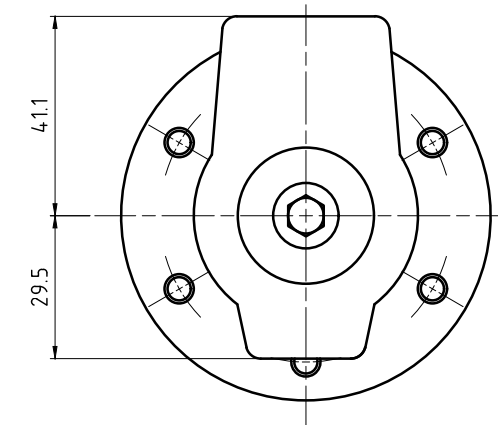
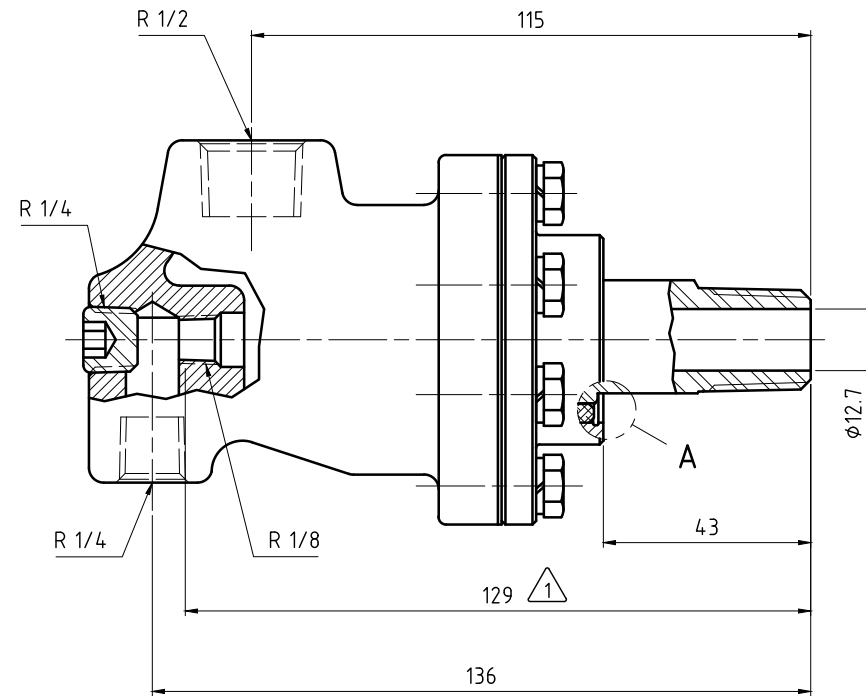
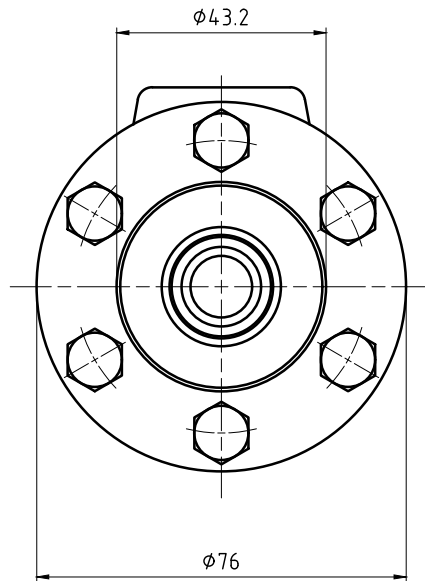

| | | | | |
|---|--------------|----------------|----------|---------------------------|
| | | PROJECTION: | | SCALE: 1:1 |
| | | MATERIAL: | | INTERFACE CONTROL DRAWING |
| | | DATE | NAME | TITLE: |
| | | DRN. 06/20/13 | N. Reyna | DEUBLIN UNION |
| | | ENGR. 06/20/13 | L. Freed | |
| | | APPD. | | |
| UNLESS SPECIFICALLY TOLERANCED, ALL DIMENSIONS ARE CONSIDERED REFERENCE | | | | NO. |
| ISSUE | MODIFICATION | ECO | DATE | SIGN |
| | | | | BC-54000-08-50B |
| | | | | SHEET A2 |