

CONFIDENTIAL

The reproduction, distribution and utilization of this document as well as the communication of its contents to others without express authorization is prohibited. Offenders will be held liable for the payment of damages. All rights reserved in the event of the grant of a patent, utility model or design.

NOTES:

- ① - CONTACT DEUBLIN OR VISIT WWW.DEUBLIN.COM FOR INSTRUCTION MANUAL: 040-550
- ② - PLUG INSTALLED HAND TIGHT FROM FACTORY. IF PORT IS NOT UTILIZED, TIGHTEN BEFORE USE.
- ③ - DEPENDING ON COUNTRY OF ORIGIN, HEX STOCK MAY VARY AS NOTED. SEE TABLE FOR ACCEPTABLE WRENCH SIZES.

Ⓢ ④ - GASKET THICKNESS.

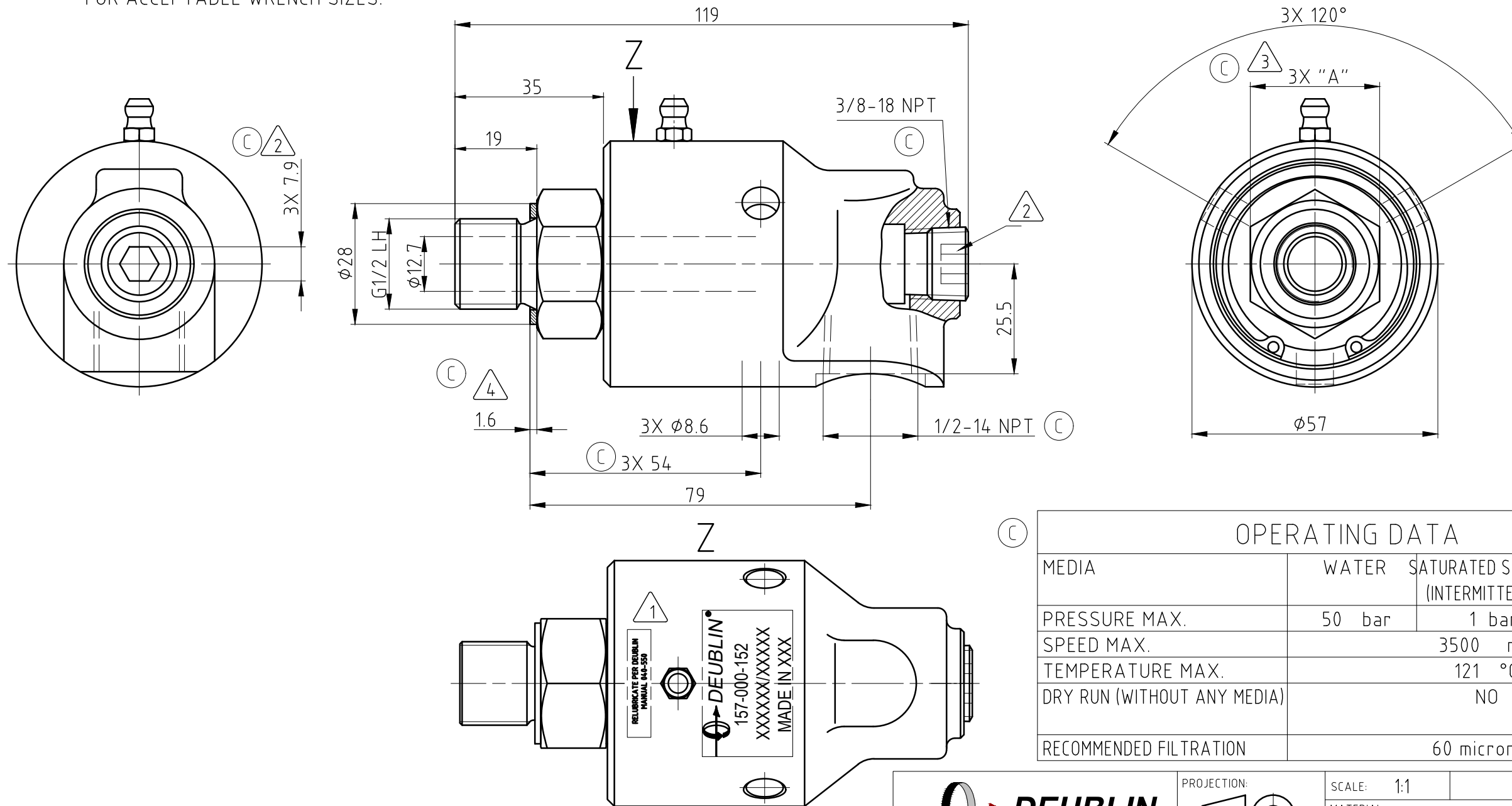

OPERATING DATA			
MEDIA	WATER	SATURATED STEAM (INTERMITTENT)	THERMAL OIL
PRESSURE MAX.	50 bar	1 bar	6.6 bar
SPEED MAX.	3500 min ⁻¹		
TEMPERATURE MAX.	121 °C		
DRY RUN (WITHOUT ANY MEDIA)	NO		
RECOMMENDED FILTRATION	60 micron		

HEX SIZES		WRENCHES	
UNITS	"A"	30mm	1 1/8"
METRIC [mm]	30-0.13	✓	☒
IMPERIAL [in]	.125-0.006	✓	✓

PROJECTION:

SCALE: 1:1

MATERIAL: INTERFACE CONTROL DRAWING

ISSUE/MODIFICATION	ECO	DATE	SIGN	DATE	NAME	TITLE:	NO.	SHEET
C	SEE ECO	058092	11/20	MZe	APPD.	DEUBLIN UNION	157-000-152	A3
B	SEE ECO	056309	05/20	MZe				
A	SEE ECO	054616	02/20	MSK				
UNLESS SPECIFICALLY TOLERANCED, ALL DIMENSIONS ARE CONSIDERED REFERENCE								