

CONFIDENTIAL
 THIS DOCUMENT CONTAINS CONFIDENTIAL AND PROPRIETARY
 INFORMATION OF DEUBLIN COMPANY. COPYING, USE,
 TRANSMISSION, DISTRIBUTION, AND DISCLOSURE ARE SUBJECT
 TO THE TERMS AND CONDITIONS CONTAINED IN YOUR
 AGREEMENT WITH DEUBLIN COMPANY. ALL RIGHTS RESERVED.

NOTES:

- 1 - WHEN ORDERING FROM DEUBLIN USE PART NUMBER: 2620-220-252.
- 2 - SEE OPERATING DATA CHART FOR P1 & P2 PASSAGE MEDIA.
- 3 - P2 PASSAGES TO BE WITHIN AREA INDICATED AND SHOULD BE SYMMETRICAL. 2X $\phi 4$ MIN. RECOMMENDED.
- 4 - ALTERNATE P2 PASSAGE (PLUGGED).
- 5 - 2X AIR SEAL OILER.
- 6 - TIGHTEN MOUNTING BOLTS TO 40 ± 5 Nm, USING A CROSS PATTERN TIGHTENING SEQUENCE.

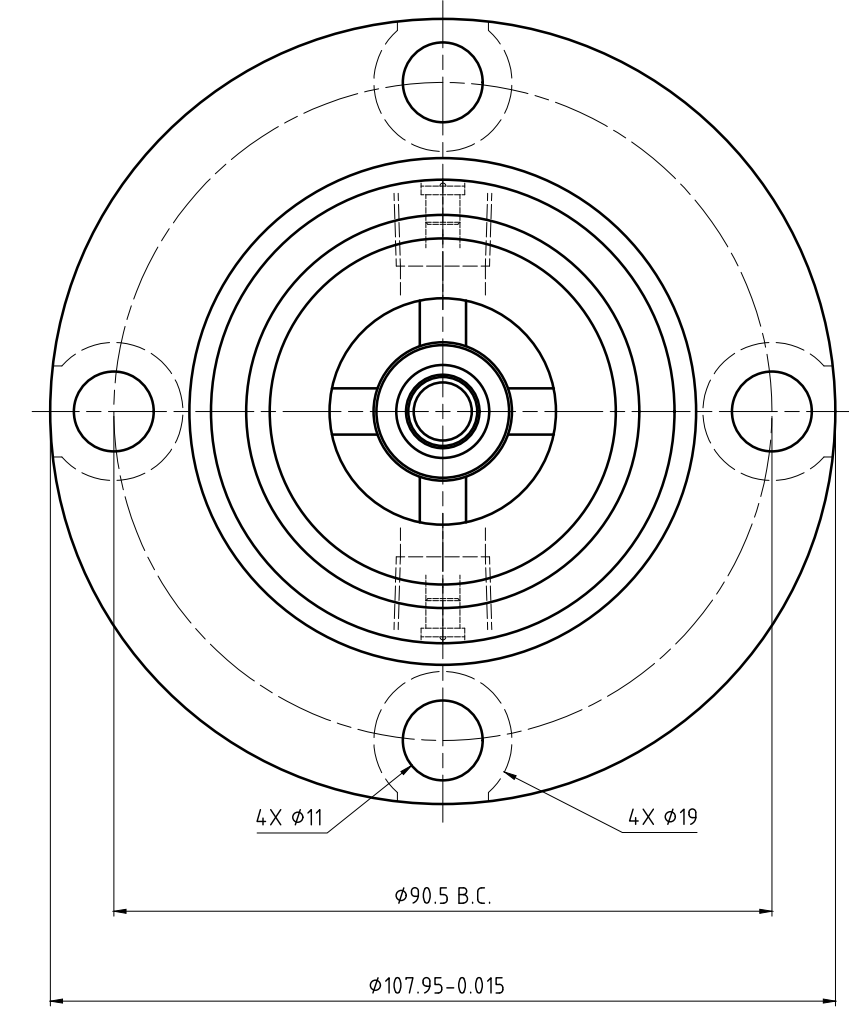
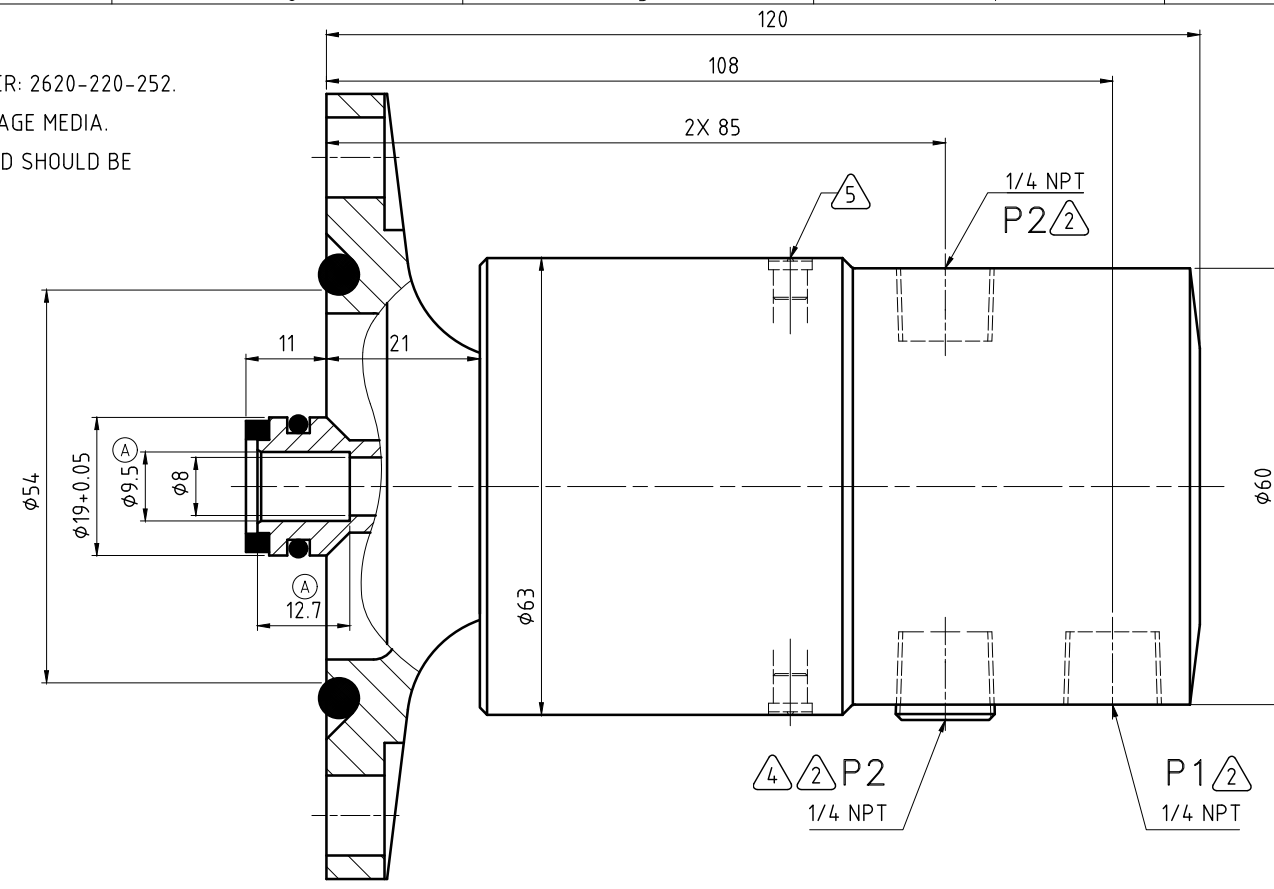

CUSTOMER INTERFACE

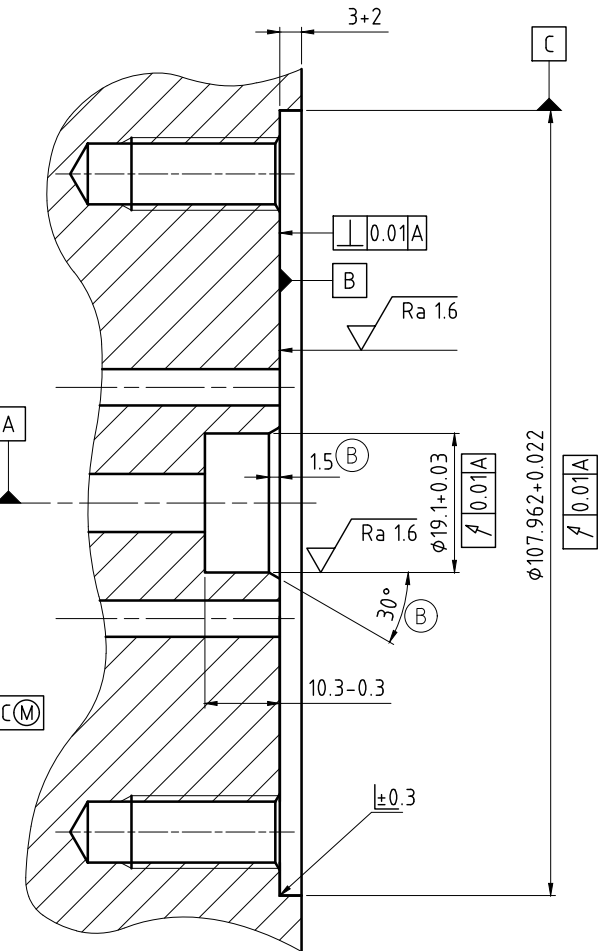
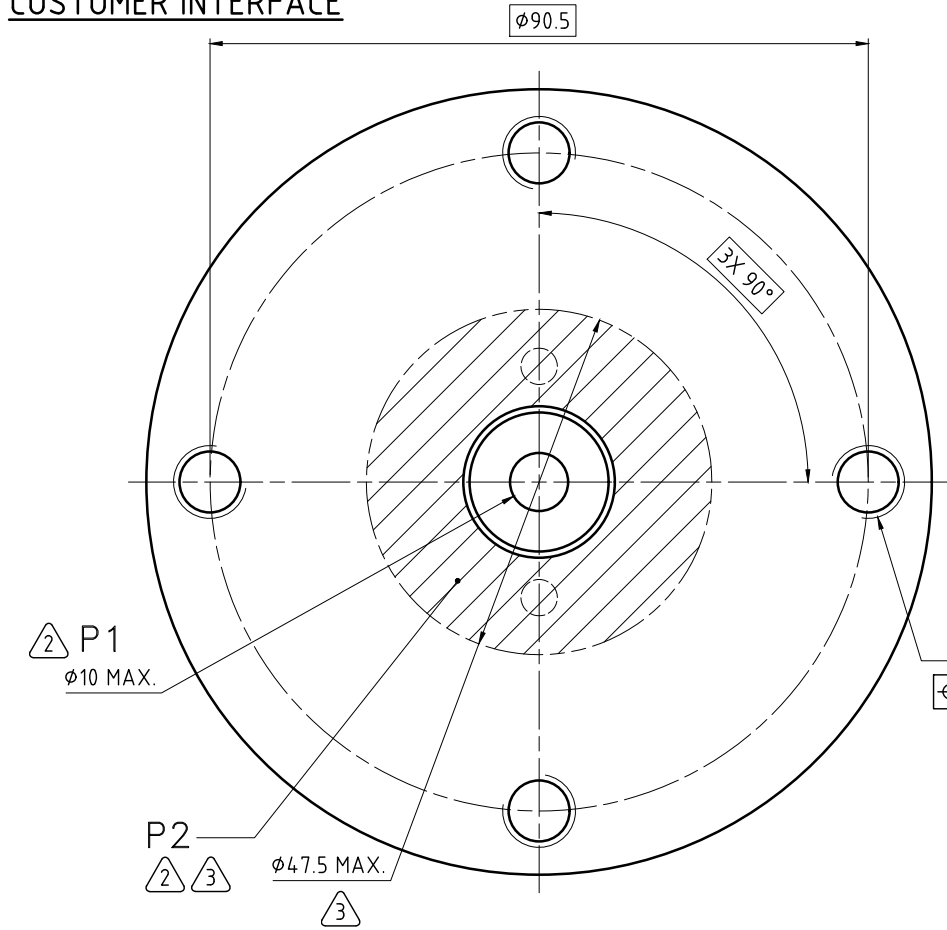

OPERATING DATA

PASSAGE MEDIA		P1 INNER	P2 OUTER
		COOLANT	AIR
PRESSURE	MAXIMUM	70 bar	10 bar
	MINIMUM	-	-
FLOW RATE	MAXIMUM	69 L/min	35 NL/sec
	MINIMUM	-	-
TEMPERATURE	MAXIMUM	71 °C	71 °C
	MINIMUM	5 °C	5 °C
DRY RUN		NO	YES
MAXIMUM SPEED		7000 min ⁻¹	

DEUBLIN COMPANY
 WAUKEGAN, ILLINOIS, U.S.A.

PROJECTION:

SCALE: 1.5:1

MATERIAL: INTERFACE CONTROL DRAWING

TITLE: DEUBLIN UNION 2-PASSAGE COOLANT INNER / AIR OUTER

NO. 2620-220-252

SHEET A2

ISSUE	MODIFICATION	ECO	DATE	SIGN	DATE	NAME
B	CHAMFER 15-30° ADDED	042096	05/17	FD		
A	#5, 121 ADDED	001800	05/08	FD		

UNLESS SPECIFICALLY TOLERANCED, ALL DIMENSIONS ARE CONSIDERED REFERENCE