

LTR	REVISION	ECO	DATE	SIGN
None	Initial Released		11/08	TW

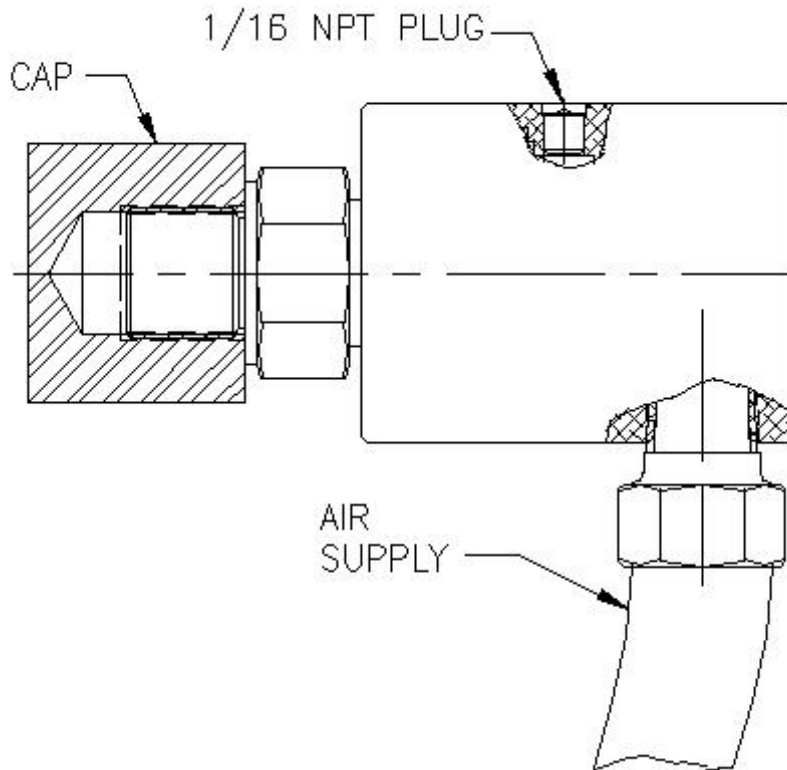

## Customer Test Instruction: 040-100



### Testing

#### Step 1

Cap rotor.

#### Step 2

Remove 1/16 NPT pipe plug from union.

#### Step 3

Pressurize union with 50 PSI minimum air pressure.

#### Step 4

Apply soap solution over 1/16 NPT hole and wait 15 seconds. If no air bubbles form & pop at test hole, then the plug is ready to be permanently installed. Apply pipe sealant before re-install pipe plug.